

PAR.1 20/150

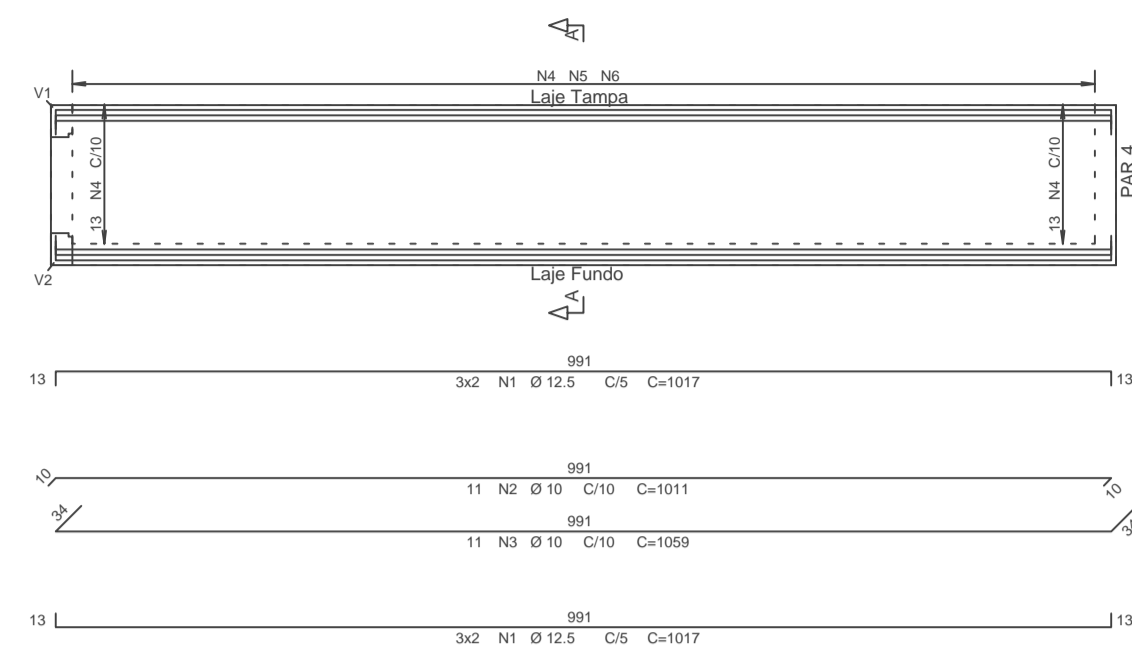

Corte A

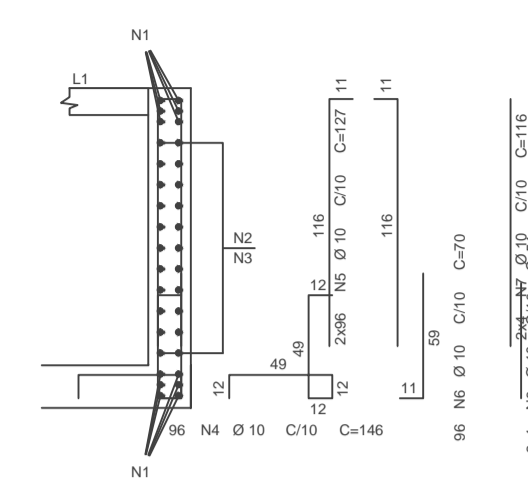

REFORÇO NOS CANTOS (Planta)

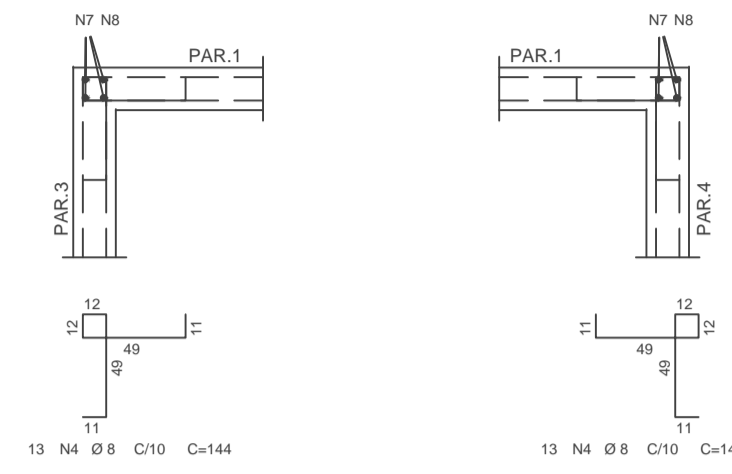

PAR.4 20/150

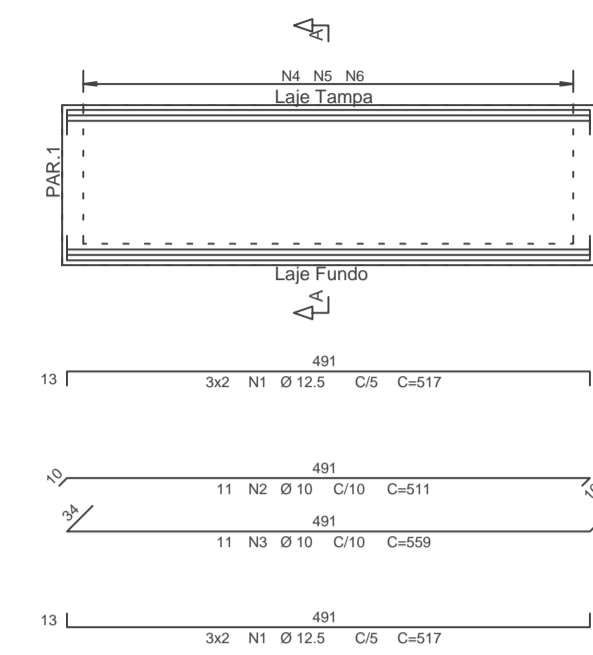

Corte A

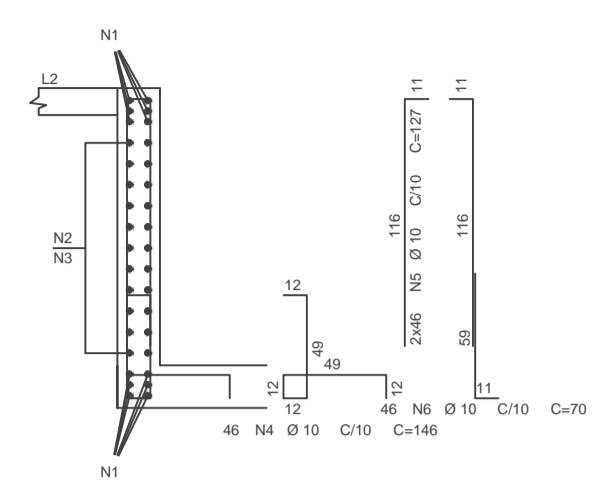

PAR.2 20/150

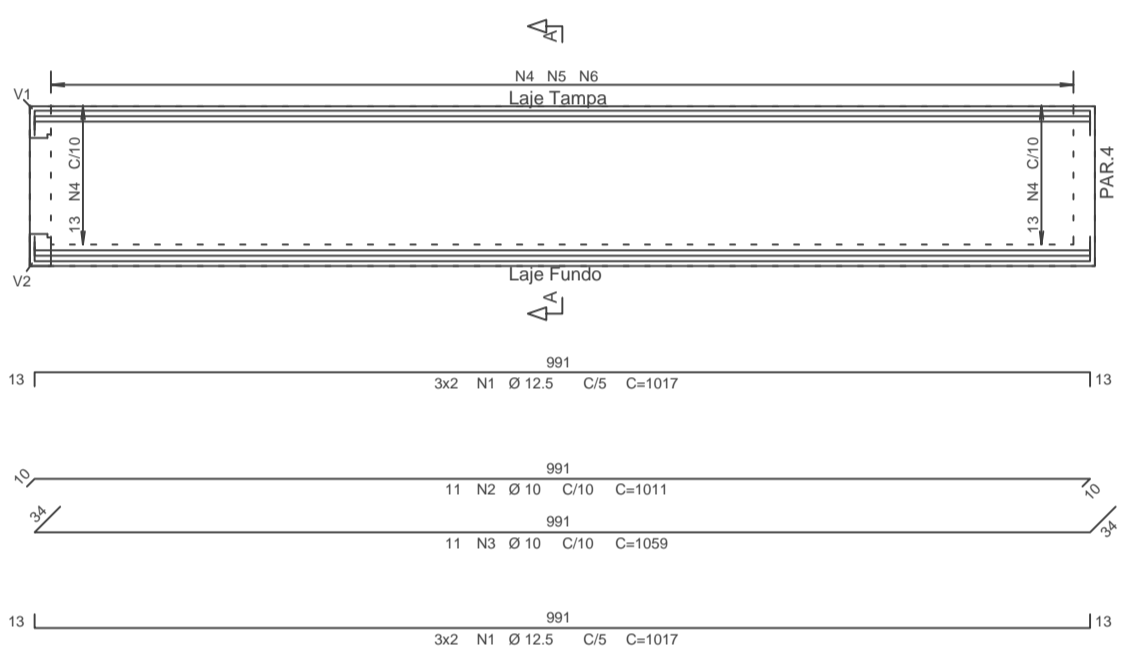

Corte A

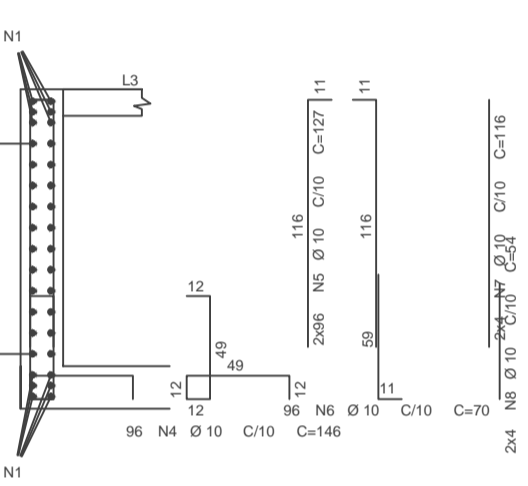

REFORÇO NOS CANTOS (Planta)

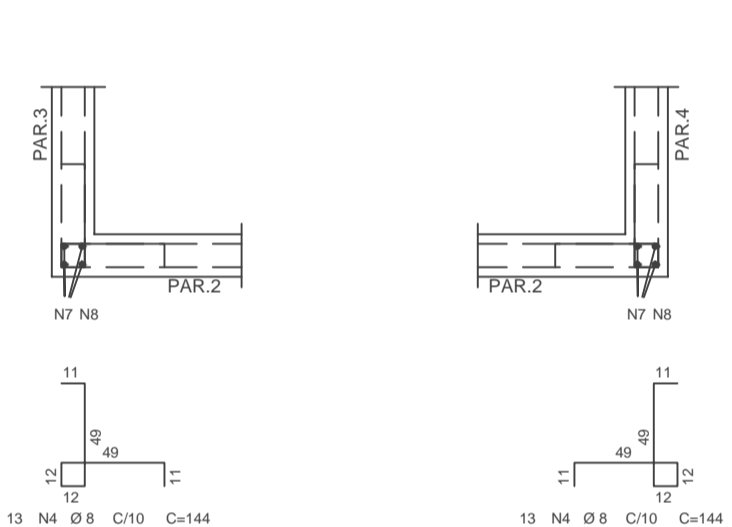

FORMA DO FUNDO DA PISCINA

ESCALA: 1/50

(LAJE h=20cm)

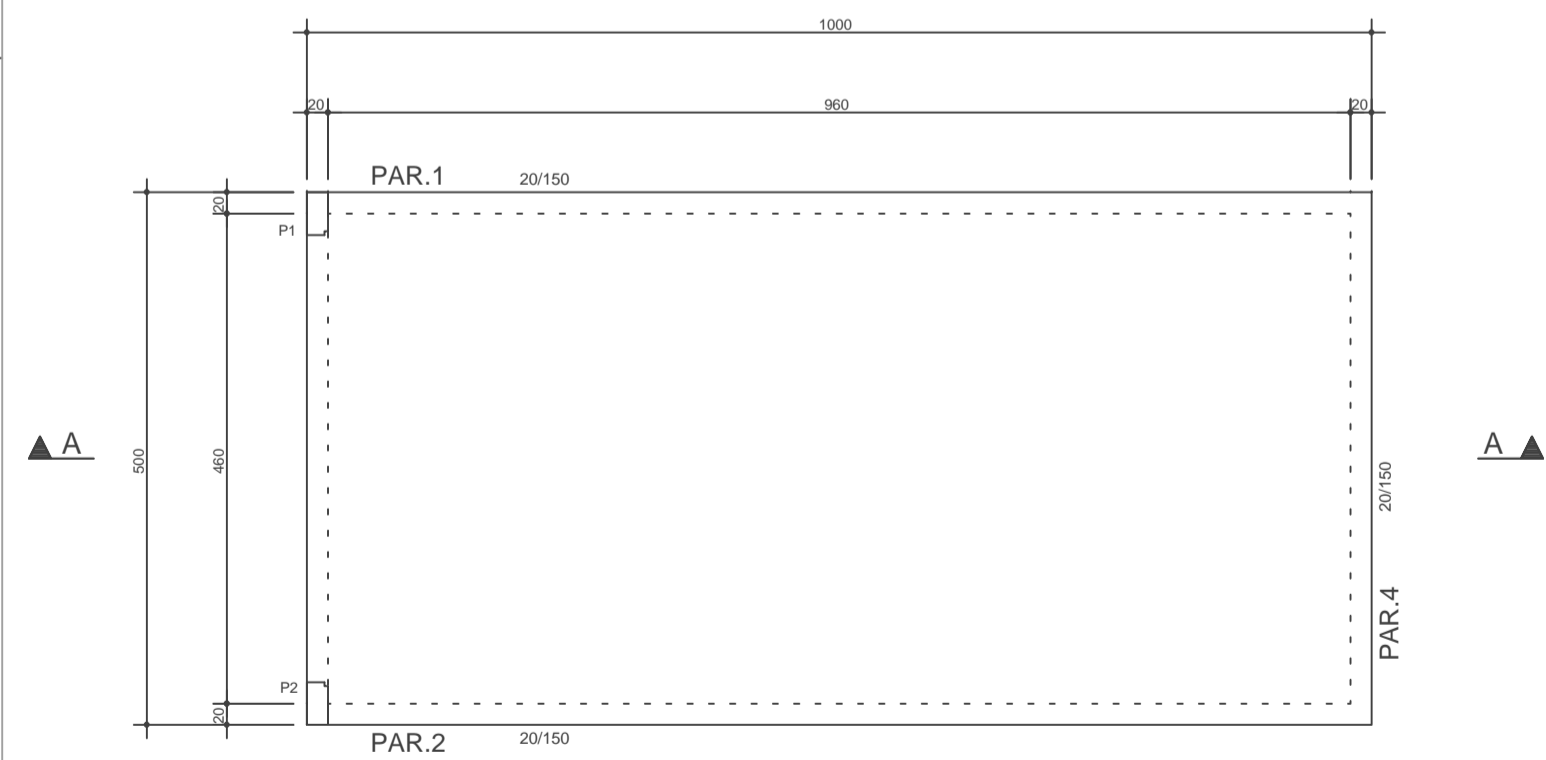

CORTE A-A



ARMAÇÃO DA LAJE DA PISCINA

ESCALA: 1/50

(LAJE h=20cm)

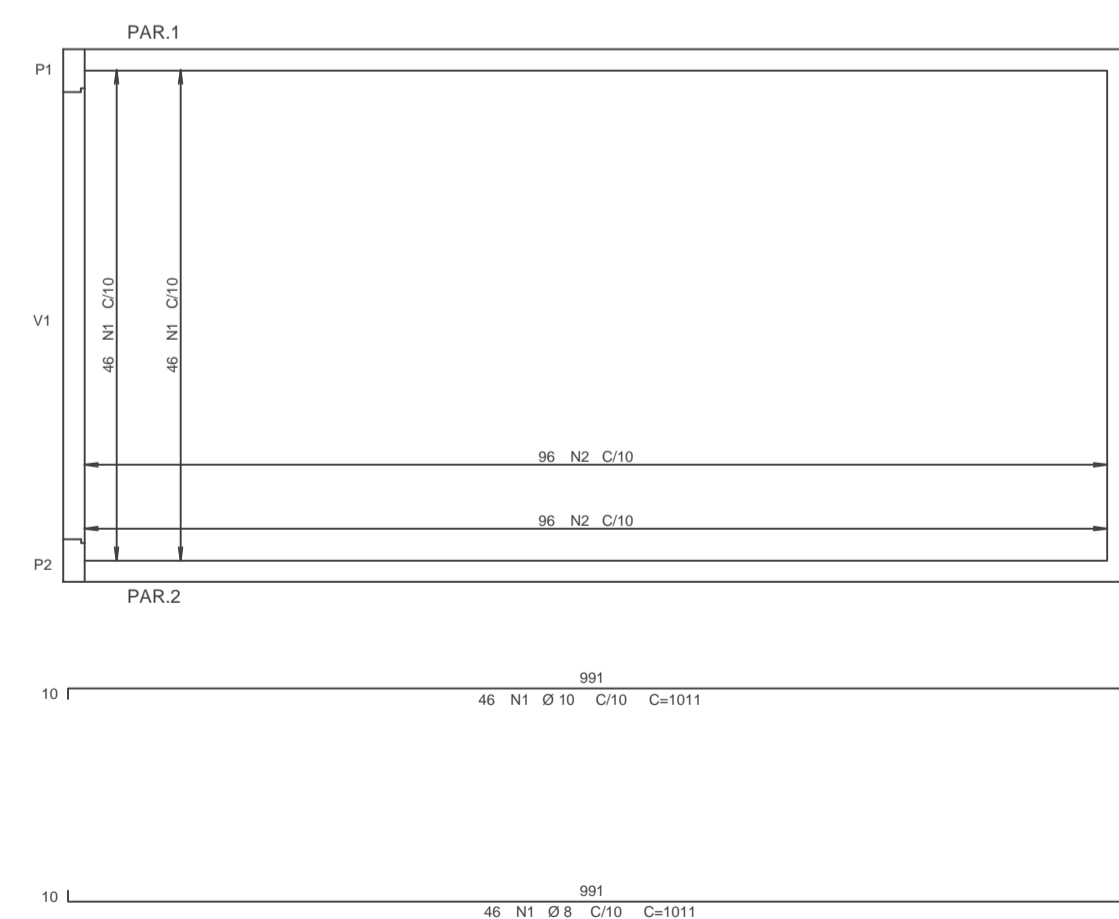

ARMAÇÃO DA LAJE DA PISCINA	AÇO	POS	BIT (mm)	QUANTI	COMPRIMENTO (mm)	UNIT	TOTAL
PAR.1	S0A	1	8	8	1011	8	8088
	S0A	2	8	8	1011	8	8088
	S0A	3	10	11	1059	11	11649
	S0A	4	10	122	146	122	17512
	S0A	5	10	192	127	192	24384
	S0A	6	10	96	70	96	6720
	S0A	7	10	8	116	8	928
	S0A	8	10	8	54	8	432
PAR.2	S0A	1	12.5	12	1017	12	12204
	S0A	2	10	11	1011	11	11121
	S0A	3	10	11	1059	11	11649
	S0A	4	10	122	146	122	17512
	S0A	5	10	192	127	192	24384
	S0A	6	10	96	70	96	6720
	S0A	7	10	8	116	8	928
	S0A	8	10	8	54	8	432
PAR.4	S0A	1	12.5	12	517	12	6204
	S0A	2	10	11	511	11	5621
	S0A	3	10	11	559	11	6149
	S0A	4	10	48	146	48	6716
	S0A	5	10	82	127	82	10504
	S0A	6	10	48	70	48	3320

RESUMO AÇO CA 50-60		
AÇO	BIT (mm)	PESO (kg)
S0A	8	1915
S0A	10	1795
S0A	12.5	306
Peso Total	S0A =	2150 kg

CONSUMO DE CONCRETO

PAR.1	3m³
PAR.2	3m³
PAR.4	1,5m³
V2	0,28m³
V1	0,28m³
P1	0,12m³
P2	0,12m³
LAJE DE FUNDO DA PISCINA	8,84m³
L1, L2 E L3	2,83m³

CONSUMO DE CONCRETO

TOTAL	19,97m³
--------------	----------------

- * ARMAÇÃO DE VIGAS E PILARES NA FOLHA 02;
- * LAJES L1, L2 E L3 NA FOLHA 01;
- * ARMAÇÕES DAS PAREDES 1, 2 E 4 NA FOLHA 03;
- * ARMAÇÕES DA LAJE DE FUNDO DA PISCINA NA FOLHA 03;
- * FORMA DA PISCINA NA FOLHA 01;

		CLIENTE CLUBE PAINEIRAS DO MORUMBY	OBR. N.º —
PROJETO DE ESTRUTURA PARA A PISCINA KIDS		DEL. N.º 03	
AV. DR. ALBERTO PENTEADO, 605			
ARMAÇÃO DA LAJE DA PISCINA ARMAÇÕES DAS PAREDES DA PISCINA		REV. N.º 00	
DATA: 19/05/2021	ESCALA: 1/50 / INDICADA	FCK: 30 MPa	PROJ. PAOLA V. BOAS RICHARD LOURENÇO